

Jubilee/Navigator Electra Switch wiring when converting to 12V with regulator/rectifier or rectifier Zener. Switch/socket viewed from the rear (after removal from bike)

Ignition

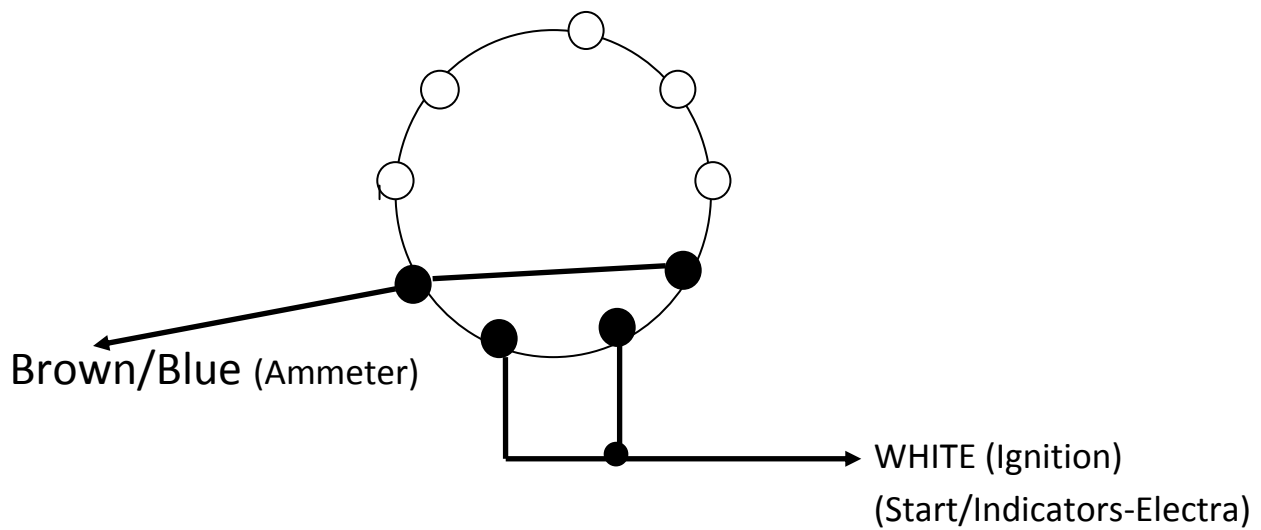

Lights

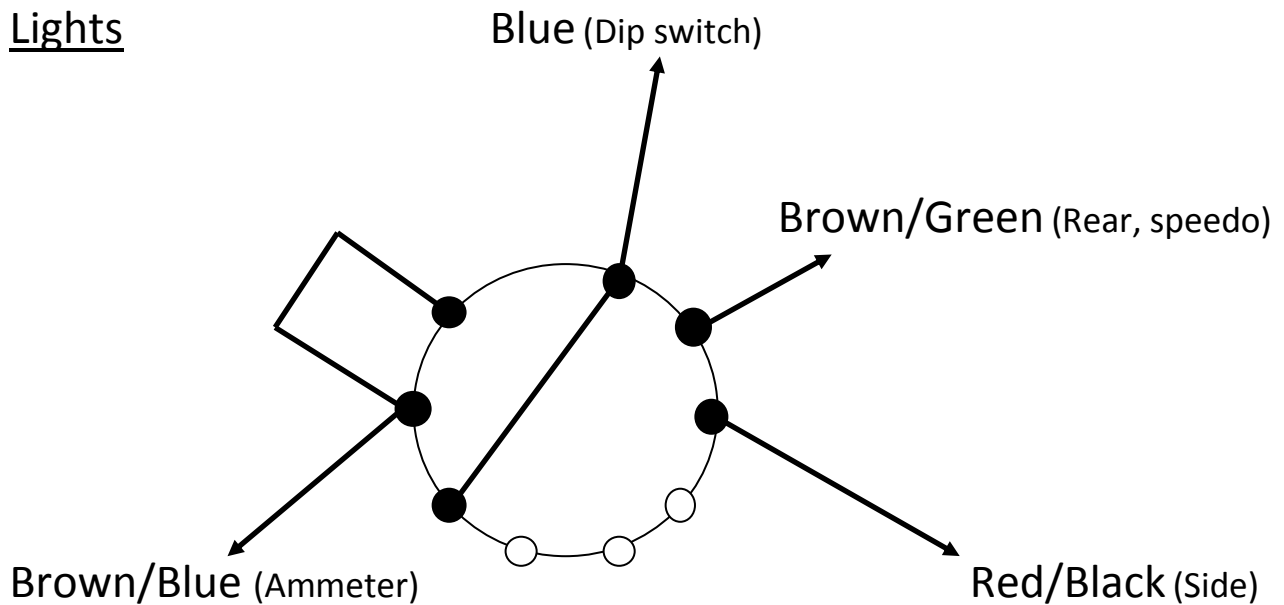

Cable colours are standardised Lucas as per 1963 and will differ from original Wipac.

Suggestion is short lengths of cable directly soldered onto switches and connected into new 'Lucas' style self made loom via bullets and Snap Connectors.